



Stayflow Econflo Series

Models T80

2PC, 1000 WOG, Threaded Ends FULL PORT

Installation, Operation and Maintenance Manual

Note: Before using a valve, read the entire IOM carefully and make sure you have a clear understanding of all information included.

This manual describes the procedures for the safe and efficient installation, operation, and maintenance of Stayflow ECONFLO Series Ball Valves. **Failure to follow the procedures in this manual may result in Stayflow warranties being voided.** Problems with the operation and maintenance of these valves should be directed to the nearest Stayflow Representative.

The Stayflow T80 is designed as a split body, two-piece construction, to allow ease of access for maintenance of the valve ball and seat without special tools. This line of valves utilizes the “free floating” ball principle. The ball is not fixed but is free to move with the line pressure. As a result, these valves are capable of tight shut-off with the flow in either direction or dead-ended, regardless of the position of the valve in the line. The downstream seat, which is opposite the pressurized side, of a closed valve, must carry the load exerted by the line pressure on the ball, while the upstream seat is subject to little load or wear. For this reason, it is sometimes possible to increase useful seat life by turning the valve end-for-end in the pipeline.

NOTE:

Please note that Model T80 is supplied in one size ranges, 1/4” to 3”.

INSTALLATION:

A. Receiving and Preparation Procedure

- A1. Remove shipping protection
- A2. Inspect the valve(s) for transportation damage*
- A3. Inspect the valve bore and remove any debris
- A4. Cycle the valve and inspect the valve for smooth operation, size permitting
- A5. As shipped from the factory, valves may contain a silicone based lubricant. This is for break-in and may be removed if it is objectionable for a particular application by disassembling and solvent washing.

*If transportation damage is found, immediately take pictures for record purposes and contact the inbound carrier to submit a claim.

B. Installation Procedure

B1. General – The valve may be fitted in any position in the pipeline. Prior to installing the valve, the pipe on either side of the intended installation should be checked to be free of dirt, debris, weld slag, etc. to prevent damage to the seats, seals, and surface of the ball. The piping must also be free of tension or compression.

WARNING – Never use the valve as a pipe support or structural member.

B2. Installation of T80 valve is accomplished by inserting the valve between the mating threads of piping specified by industry standards.

Caution – Ensure that mating threads are of the same size and thread standard.

B3. Valves with actuators should be checked for actuator-valve alignment. Angular or linear misalignment will result in high operational torque. Electric and/or pneumatic connections should be made in accordance with the correct actuator IOM instructions.

C. OPERATION:

C1. Manual operation of the valve is accomplished by turning the handle ¼ turn (90 degrees).

*The valve is open when the handle is “in-line” with the valve or pipeline. The valve is closed when the handle is “across” or perpendicular to the valve or pipeline.

C2. Stayflow ECONFLO Series valves can be operated with either electric or pneumatic actuators. Please consult factory for installation.

C3. Stayflow ECONFLO Series valves may include one of several different styles of limit switches and positioners. Please refer to the appropriate IOM for each device.

MAINTENANCE:

CAUTION – Ball valves can trap fluid in the ball cavity when closed. Be prepared to capture and manage any liquid retained in the valve body when disassembling the valve.

WARNING – **If the valve has been in hazardous fluid service, review applicable MSDS sheet and decontaminate the valve before disassembly. All persons involved with the disassembly should wear personal protection equipment such as aprons, gloves, face shield, etc. to prevent personal injury.**

Access to the valve internals starts with relieving pressure in the pipeline. Turn the valve handle to the 45 degrees, half open, position and flush the line, when applicable, to remove any hazardous material from the line. Repair kits can be ordered from the local Stayflow Representative. This should be done prior to any disassembly work.

CAUTION - Valves with actuators, limit switches or positioners should have these devices disassembled from the valve prior to disassembling of the valve.

WARNING- **Use extreme caution disconnecting any electrical and/or pneumatic sources to the valve to protect against personal injury. Isolate the valve actuator prior to disconnecting.**

Stem Packing

Stem seal leakage may be corrected without disassembly. Tighten the packing gland nuts one flat at a time alternating between nuts, until leakage stops. If leakage continues, or the valve's operating torque becomes excessive, the seals are worn and replacement of the packing will be necessary.

WARNING- **Do not remove packing gland while the line is under pressure. Personal injury could occur.**

D. Valve Disassembly-

WARNING – **Use extreme caution when removing the valve from the pipeline to prevent personal injury.**

CAUTION – valves shall be adequately supported prior to unthreading that hold the valve in line and secured with lifting straps or slings to hold the weight of the valve.

- D1. Remove handle nut, handle washer and handle.
 - D2. Remove packing gland.
 - D3. Remove seat in threaded end cap.
 - D4. Remove ball from body, care should be taken not to scratch the ball during disassembly.
 - D5. Remove stem into body, taking care not to pinch or nick stem packing
 - D6. Remove the thrust washer, o-ring, packing protector on stem O.D.
 - D7. Remove stem packing in valve body.
 - D8. Remove seat in the rear of the body cavity with the spherical curvature facing the mating ball.
 - D9. Safe and proper bench testing is required before re-installing to service. Ensure that valve operates smoothly.
- CAUTION** – Use extreme care in handling the ball to avoid damage.

The stem must be removed from the inside of the body. Gently tap the top of the stem with a non-metallic mallet. The thrust washer should come out with the stem. Stem packing can now be removed. If a packing pick is used to remove packing, care must be taken not to scratch any surface.

Visual Inspection-

Clean and inspect all metal parts. It is not necessary to replace the ball and stem unless the seating surfaces have been damaged by abrasion or corrosion. Stayflow strongly recommends that all seats, seals, and packing be replaced whenever a valve is disassembled for reconditioning. This is the surest protection against subsequent leakage after reassembly. Replacement parts are sold in kit form. Kits can be obtained via the local Flo- Tite Distributor. Replacement parts should be purchased prior to valve disassembly. Required information to purchase replacement parts include:

- a. Line size
- b. Model designation
- c. Seat/seal materials

Valve Reassembly -

Note- the valve may be reassembled and operated dry when no lubricants are allowed in the system; however, a light lubricant on the ball and stem will aid in assembly or reduce initial operating torque. The lubricant used must be compatible with the intended system fluid.

Install one new seat and seal in the body cavity with the spherical curvature facing the ball. Replace the stem in the reverse order from above based on valve size, including reattaching the handle. Turn the valve handle to the 90 degree to bring valve to closed position. This will align the stem tang and the ball slot. Slide the ball into position. Turn the handle to the open position to help hold the ball in place. Install the second seal and seat into the body end. Place the body seal gasket into the shoulder counter-bore in the valve body.

Note: Make sure ball is in closed position before tightening up the end connections.

Cycle the valve slowly, with a gentle back and forth motion to build gradually to a full quarter turn. By cycling slowly, the new seat lips will conform to the seal shape against the ball. An initial fast turning motion, at this point, may cut the seats before they have a chance to form the proper seal. When possible and practical, test the valve prior to reinstalling into the pipeline.

Reinstallation

Carefully inspect the faces of both the valve and the mating threads to ensure they are clean and undamaged. Place the valve in the preferred position and support it from moving.

Repair Kits –

Repair kits typically consist of replaceable seats, body seals and packing seals.

Stayflow's marking system follows MSS SP-25-1998

Valve Markings- Casted into valve bodies include the following; Stayflow Name, Model Numbers, Body Material, Valve Size.

Standard Trim Soft Parts

ID-Codes
Stayflow

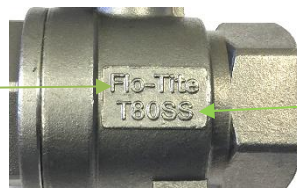

Valve Side A

Model Number

Body Rating



Valve Side B

Body Material

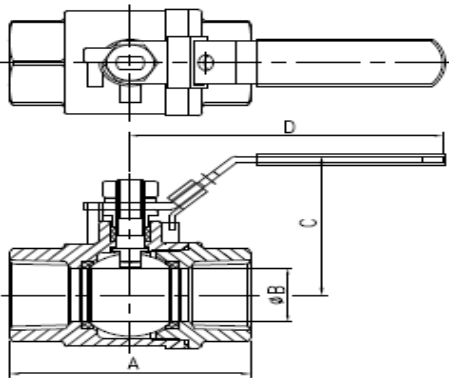

DIMENSIONS AND WEIGHTS:

SIZE	1/4"	3/8"	1/2"	3/4"	1"	1 1/4"	1 1/2"	2"	2 1/2"	3"	
A	inch	1.97	2.05	2.32	2.72	3.15	3.62	4.13	4.84	5.91	6.69
	mm	50	52	59	69	80	92	105	123	150	170
B	inch	0.43	0.43	0.49	0.79	0.98	1.26	1.50	1.97	2.56	2.99
	mm	11	11	12.5	20	25	32	38	50	65	76
C	inch	2.09	2.09	2.09	2.22	2.58	2.80	3.15	3.52	5.06	5.14
	mm	53	53	53	56.5	65.5	71	80	89.5	128.5	130.5
D	inch	3.70	3.70	3.70	3.70	4.37	4.37	5.37	5.37	9.57	9.57
	mm	94	94	94	94	111	111	136.5	136.5	243	243
Cv		7	7	10	35	68	110	155	300	500	600
Torque (in-lb)		50	54	59	85	150	234	344	476	875	1330
Weight (lbs)		0.5	0.5	0.58	0.91	1.51	2.33	3.51	5.73	11.75	17.12

BILL OF MATERIALS:

Item	Name	T80SS	T80CS	QTY
1	Body	ASTM A351 CF8M	ASTM A216 WCB	1
2	End Cap	ASTM A351 CF8M	ASTM A216 WCB	1
3	Ball	ASTM A276 Type 316	ASTM A276 Type 304	1
4	Seat	PTFE	PTFE	2
5	Body Seal	PTFE	PTFE	1
6	Stem	ASTM A276 Type 316	ASTM A276 Type 304	1
7	Thrust Washer	PTFE	PTFE	1
8	Stem Packing	PTFE	PTFE	2
9	Gland Nut	SS304	SS304	1
10	Handle	SS304	Zinc Plated Steel	1
11	Locking Device	SS304	Zinc Plated Steel	1
12	Lever Sleeve	PVC	PVC	1
13	Spring Washer	SS304	SS304	1
14	Nut	SS304	SS304	1

Dimensions are for estimating purpose only. Please consult factory for exact dimensions.

All valves 100% air tested underwater at 100 psi Open and Close positions.

T80SS Conforms to:
Federal Specification WW-V-35B
Type II, Class C Style 3

Pipe Thread in accordance with
ANSI B1.20.1

Note: Our T80 Series Valves Are Not Designed To Be Actuated. Please See Our T23 Series Tech Bulletin Page 14

PRESSURE AND TEMPERATURE DATA

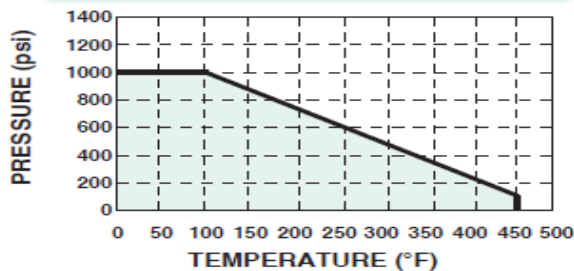

PRESSURE RATING: 1000 WOG

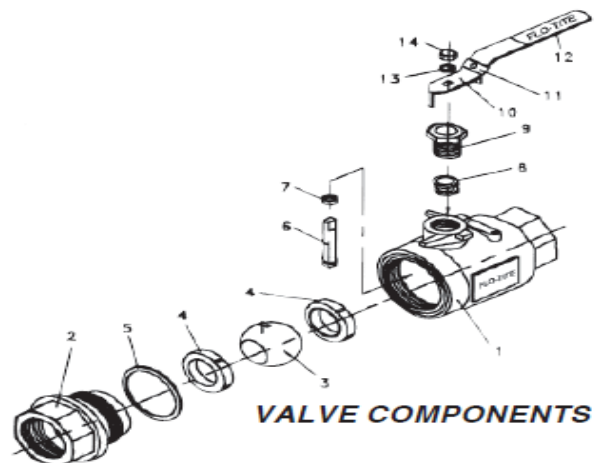

VALVE COMPONENTS