

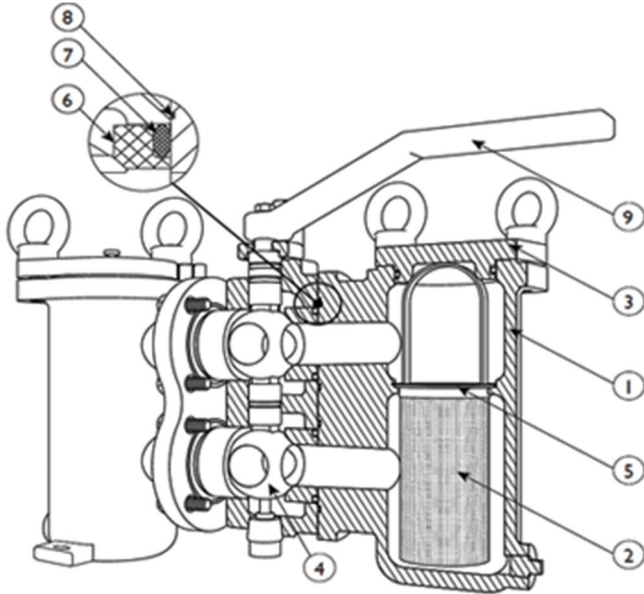

**DBFT Flanged &
DBTT Threaded
Aluminum Bronze
Duplex Strainers**

150# Class

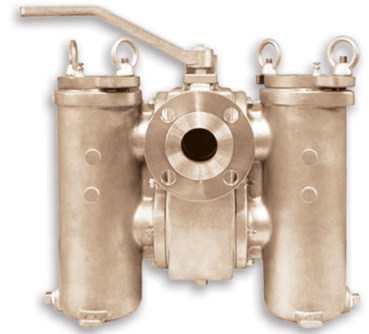

**PRESSURE RATING (psig)
ANSI CLASS 300**

W.O.G.	TEMP RANGE		SEAL - MAX (F)	BODY - MAX (F)
195 @ 100 F	-20 to 250F		250 F	250 F

FORGED STEEL THREADS - PER ASME/ANSI B16.11

PIPE FLANGES - PER ASME/ANSI B16.5

BILL OF MATERIALS

ITEM	DESCRIPTION	MATERIAL
1	Housing	Aluminum Bronze ASTM B148
2	Straining Element	Stainless Steel
3	Cover	Aluminum Bronze ASTM B148
4	Ball	Stainless Steel
5	O-ring	Buna-N
6	Seat Seal	PTFE
7	Seals	Buna-N
8	O-ring Body	Buna-N

DEFAULT SCREEN - 1/16" PERFORATIONS, 41% OPEN AREA

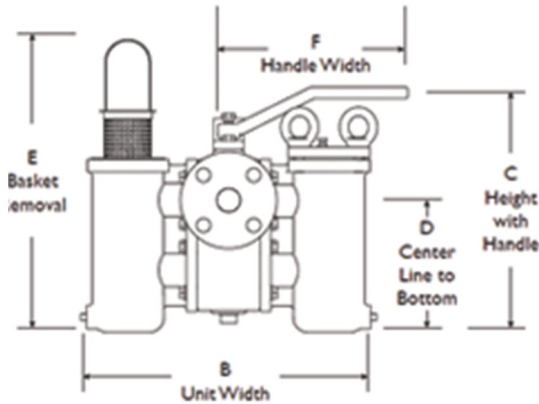
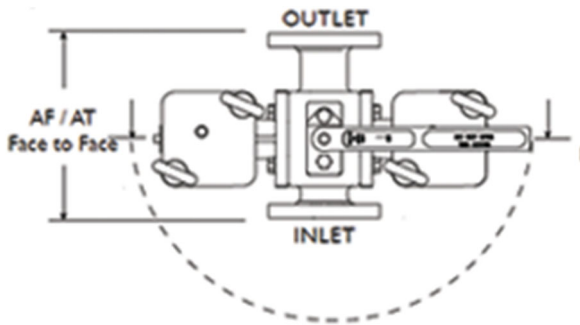

DIMENSIONS (in) / PERFORMANCE

SIZE	AF	AT	B	C	D	E	Cv
3/4	NA	5.59	12.95	12	5.83	15.4	13
1	7	5.59	12.95	12	5.83	15.4	14
1-1/4	9.37	7.5	15.12	14.8	8.3	21.3	19
1-1/2	9.37	7.5	15.12	14.8	8.3	21.3	24
2	10.6	10.0	18.43	18.4	10.7	26.4	42
2-1/2	13.5	11.5	22.05	22.7	13.7	35.0	68
3	13.5	11.5	22.0	22.7	13.7	35.0	105
4	16	NA	26.85	25.5	15.9	41.0	180

* AT=THREADED DIMENSION (Threaded version available from 3/4"-3" sizes)